

TECHNICAL FEATURES

Back view

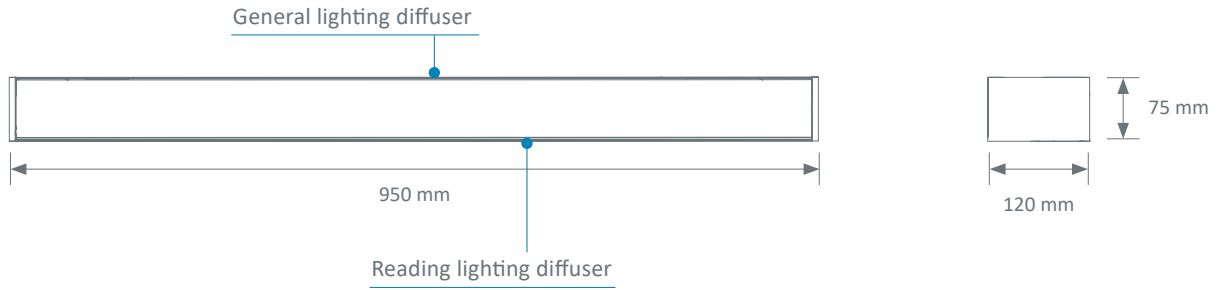

Colours

	GREY RAL 9006	GREY RAL 9007	WHITE RAL 9016
GOODLIGHT	●	●	●



CONTROLLED LIGHTING

The GOODLIGHT wall lighting unit is equipped with LED sources. It provides comfortable, high-quality lighting for patients and care teams.

High-performance comfortable and controlled lighting

The reading light diffuser provides soft, comfortable lighting. The patient, medical personnel, or visitors, because the sources are not directly visible.

General lighting

- Clear satin-finish PMMA* diffuser with anti-UV treatment
- MIRO 20 SILVER® Aluminum reflector

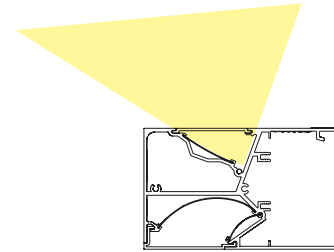

Reading lighting

- Satin-finish polycarbonate direct diffuser
- MIRO 20 SILVER® Aluminum reflector

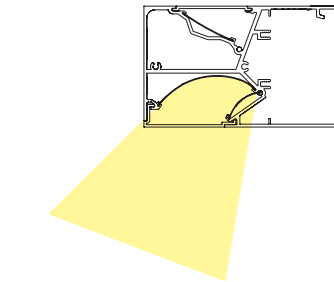

Caring lighting

Caring lighting combines direct (reading) lighting with indirect (general) lighting.

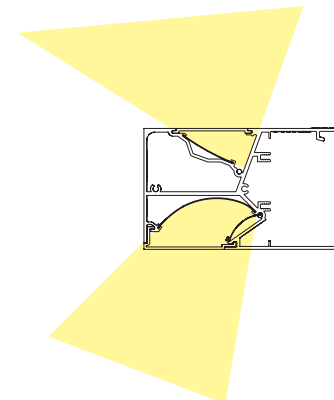

* PMMA: Polymethyl methacrylate

EFFICIENT LIGHTING

Lighting study

- Standard room
- Dimensions of the room: 3 m x 3 m, ceiling clearance 2.5 m
- Reflection coefficients: ceiling 7, walls 5, and floor 3
- Coefficient of depreciation 0.83

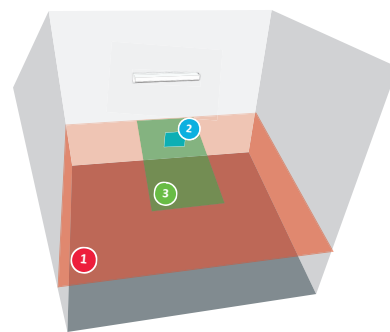

LED	General lighting Virtual general lighting plane of a surface equal to the one of the room, located 0.85 m above the floor (3 m x 3 m for a single room).	Reading lighting Virtual reading plane 0.3 m x 0.3 m inclined at 75° located 1.1 m from the floor and 1 m from the wall where the light fitting is mounted.	Caring lighting Virtual examination plane 2 m x 0.9 m located 0.85 m from the floor, centred in width and 0.1 m from the wall.
	3 ft module 	2 ft module 	General and reading lighting combined
Consumption	33,2 W	10,8 W	44 W
Average lighting	125 lx	350 lx	379 lx

Lighting power

Lighting	Modules power	Types of sources	Color temperature	Luminous Flux ⁽¹⁾	Consumption	System Efficiency	Driver(s)	Efficiency energy class
General lighting	28,7 W (3 Ft)	LED	3000 K 4000 K	5039 lm	33,2 W	151,9 lm/W	Fixed / DALI	
General lighting (Dynamic lighting)	38,9 W (3 Ft)	LED	2700 K to 6500 K	5000 lm	44,9 W	111,4 lm/W	DALI	
Reading lighting	8,9 W (2 Ft)	LED	3000 K 4000 K	1710 lm	10,8 W	158,8 lm/W	Fixed / DALI	
Night light	1 x 3,1 W	LED	3000 K	335 lm	4,9 W	68,1 lm/W	Fixed	

⁽¹⁾ All the luminous flux indicated in the brochure are based on the flux of the LED modules also known as system flux.

Luminaire output flux = (Module flux) x (optical efficiency), the optical efficiency of the luminaire is indicated in the Eulumdat file (LDT line 23) available for download on our website or on request.

Dynamic Lighting



The GOODLIGHT wall lighting unit is available with dynamic lighting.

For more information, please read the dedicated brochure.



Norms & certifications

- Low Voltage Directive (LVD) 2014/35/UE
- Directive 2014/30/UE: Electromagnetic Compatibility (EMC)
- EN 60598: Luminaires - Part 1: General requirements and tests - Part 2-25: Luminaires for use in clinical areas of hospitals and health care buildings
- Article EC5 safety regulation against the risks of fire and panic in establishments open to the public ERP
- European rules for caring centers lighting

Bed head units, Wall lighting units, Ceiling pendants, Suspended Beams & Columns,
Special care bed head units, Sealed lightings, Medical gas monitoring & Biomedical Accessories

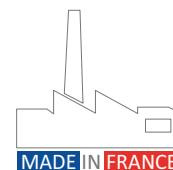

* Energy Efficiency Index - All specifications here in are provided for information purposes only and may be modified by TLV without notice. (C) - Update(LJ/MM/AA) : 23/02/2023