

FEATURES

The ceiling-mounted pendant from the TECH-CARE Ergofix range satisfies most requirements of healthcare professionals. It provides convenience and safety when transporting biomedical devices and accessories.

Its custom technical and ergonomic configuration provides modularity and a radius of movement from 45° to 315°. The flexibility of the arms optimizes patient access, working conditions, and cleaning of treatment areas.

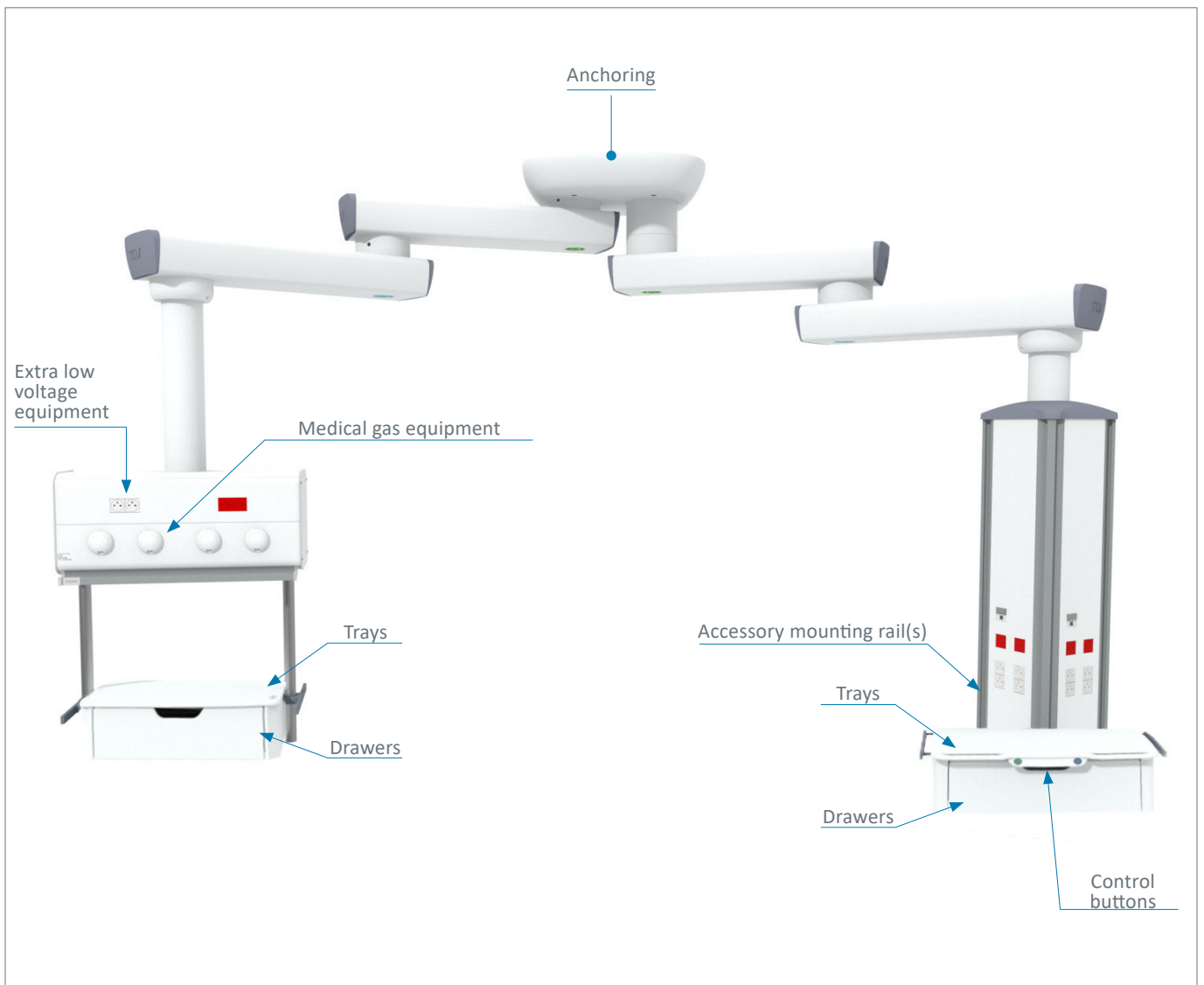

The TECH-CARE pendant allows horizontal extension of 500 to 2000 mm according to configuration. Its standard version is equipped with a mechanical friction rotation braking system, and an optional electromagnetic braking system is available.

The new boxes are designed to be ergonomic and user-friendly for all care teams. They distribute extra-low/low voltage and medical gases.

Technical characteristics of boxes

Vertical 2 sides

- Aluminum profile
- High loading capacity : 150 kg
- Three heights for vertical box: 600, 1200 or 1500 mm
- Equipped with three accessory mounting rails 25 x 10 mm (two on the front panel and one on the back)
- Can be equipped with optional LED lighting located in the lower section



Vertical 4 sides

- Aluminum profile
- High loading capacity : 150 kg
- Two heights for vertical box : 1000 or 1200 mm
- Equipped with four accessory mounting rails 25 x 10 mm
- Can be equipped with optional LED lighting located in the lower section



Horizontal

- RAL 9016 white lacquered steel body
- Loading capacity : 150 kg
- L x H x P (without rail) : 760 mm x 324 mm x 267 mm
- Equipped with two vertical \varnothing 38 mm accessory support tubes, 800 or 1500 mm long



Controls with illuminated button

They are located on the front panel of the tray, allowing easy and ergonomic use of the motorized arm braking.

With their color coding, they allow intuitive operation of the arm.



Controls and handles



Control with tray



Offset handle for light loads



Heavy duty handle

Trays & Drawers

The trays are designed to comply with the strictest standards concerning hygiene and durability. Their surface is compact with white core (HPL), and they have lateral accessory mounting rails 25 x 10 mm.

The tray units can accommodate one or two drawers. The ergonomic handles built into the trays make it easy to handle the arm. The drawers are removable for easy cleaning.



Accessory support bracket for double-sided enclosure

This device clamps onto the vertical service head and makes it possible to hang main biomedical accessories.



● Trays and drawers for horizontal box

Trays

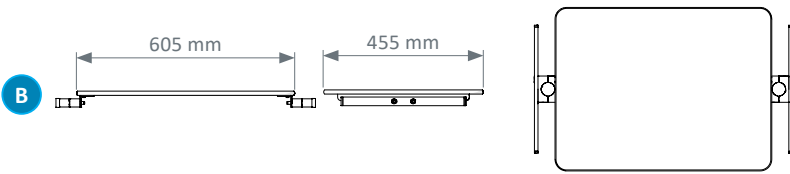

One drawer

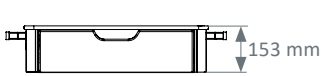

Two drawers

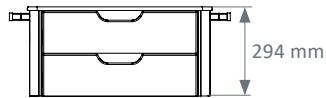

● Trays and drawers for double-sided vertical cabinet

Trays

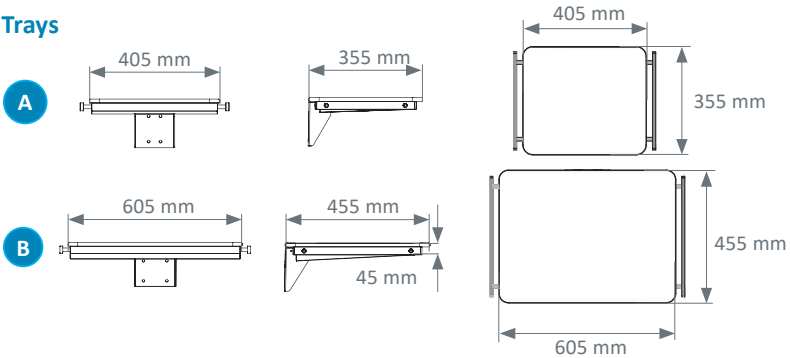

One drawer



Two drawers

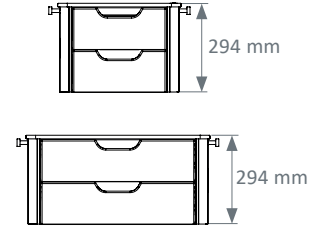

Load table

	TRAY DIMENSION	LOAD MAX
A	405 x 355 mm	40 kg
B	605 x 455 mm	50 kg

Optional features

High flow DALI circulation light



CONFIGURATIONS

Mono configuration : single arm



Mono configuration : double arms



Vertical column configuration



Duo configuration : single arms



Duo configuration : double arms and single arms



Duo configuration : double arms



Duo configuration : double arms and vertical column



TECHNICAL CHARACTERISTICS

Ceiling mounted	Anchoring under concrete slab measuring up to 1500 mm
Configuration	Mono ou duo
Arm lengths	500 mm, 750 mm et 1000 mm
Rotations	Arm : 45 to 315°, stop indexing every 25,5° Box : 30 to 330°
Rotation braking	Arm : adjustable mechanical (standard) or electromagnetic (optional) Box : adjustable mechanical
Colors	White RAL 9016

Arm configurations		Maximum load at the end of the boom (excluding distribution boxes)	Maximum load per distribution box * 2 sides under one arm	Maximum load per distribution box ** 4 sides under one arm	Maximum load for a 2 sided column	Maximum load for a 4 sided column
Arm 1	Arm 2					
500		420 KG	150 KG	200 KG	150 KG	200KG
750		380 KG				
1000		340 KG				
500	500	340 KG	150 KG	200 KG	150 KG	200 KG
500	750	290 KG				
500	1000	250 KG				
750	500	290 KG	150 KG	200 KG	150 KG	200 KG
750	750	260 KG		180 KG		
750	1000	230 KG				
1000	500	250 KG	150 KG	200 KG	150 KG	200 KG
1000	750	230 KG		180 KG		
1000	1000	210 KG		160 KG		

* The carrying capacity is the maximum acceptable load on the distribution box. This value should be reduced by the weight of the trays and accessories supported by the box. Therefore TLV mentions the acceptable weight by visible label on each box, rail and tray, avoiding the risk of overload.

** Based on a 50 kg four-sided box. Please contact us for any other load.

Norms & certifications

- EN ISO 13485 : Quality management systems
- CE Medical Devices Marking according to the (EU) Rules 2017/745
- EN ISO 11197: Medical supply units
- EN ISO 7396: Medical gas pipeline systems - Part 1 and 2

Bed head units, Wall lighting units, Ceiling pendants, Suspended Beams & Columns,
Special care bed head units, Sealed lightings, Medical gas monitoring & Biomedical Accessories

